

# Slimline Twin Duo Carrycot

Instruction manual

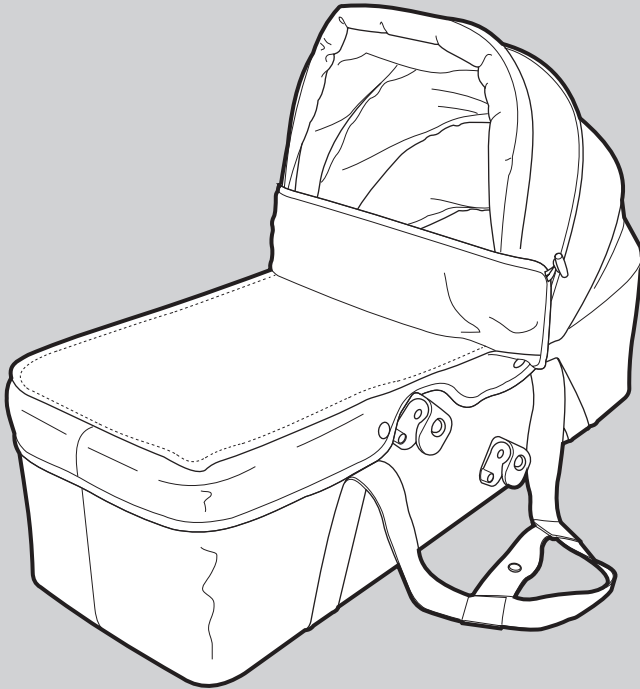

## **IMPORTANT: READ CAREFULLY AND KEEP FOR FUTURE REFERENCE.**

This product is suitable only for a child who cannot sit up unaided, roll over and cannot push itself up on it's hands and knees.

Maximum weight of the child: 9kg.

This product is tested to: BS EN 1888-1:2018+A1:2022 & BS EN 1466:2023

## Safety warnings

### WARNING

Never leave your child unattended.

Ensure that all the locking devices are engaged before use.

To avoid injury ensure your child is kept away if unfolding and folding this product.

Do not let your child play with this product.

Do not let other children play unattended near the carrycot.

Check that the pram body, pushchair body or seat unit attachment devices are correctly engaged before use.

The carrycot is suitable from birth until the child can sit up unaided. This product is suitable only for a child who cannot sit up unaided, roll over and cannot push itself up on it's hands and knees. Maximum weight of the child: 9kg.

Do not use or add a mattress other than the one supplied with the carrycot. Only use replacements approved by the manufacturer. Do not add another mattress on top of the one provided.

This product is designed to carry only one child at a time.

Never use your carrycot on a stand.

Use only on a firm, horizontal level, flat and dry surface.

NEVER place the carry cot near open fires or other sources of strong heat, such as electric bar fires, gas fires, etc.

Do not leave flexible carrying handles inside the carry cot.

The child's head should never be lower than the child's body whilst in the carry cot.

Always be aware of the hazard of bumping the baby e.g. when placing the carrycot on the floor or going through doorways.

Never leave anything in the carrycot that could present a danger of suffocation e.g. non-rigid toys, pillows etc.

NEVER place the carrycot next to or near an item that could present a threat of strangulation, such as blinds, curtain cords, strings etc.

Overheating can endanger the life of your child. Take into account the ambient temperature and the child's clothing and ensure the child is not too cold or warm.

Ask a health professional for further advice on safe sleeping for babies and infants.

## Safety warnings (when attached to the compatible Travel System)

### WARNING

This pushchair is not suitable for running or skating.

Always apply the brakes when the pushchair is stationary, and when placing and removing children. When the parking brake is used, always test it is properly applied by pushing on the handle of the pushchair.

Do not lift and carry the pushchair with a child in it.

Ensure that children are clear of moving parts before making adjustments.

Taking children up or down stairs, escalators, steps, steep slopes and muddy/rough terrain could be dangerous and should not be attempted. Remove your child from the pushchair for easy carrying to negotiate such hazards, or simply avoid them.

Do not use replacement parts or accessories other than those approved by the manufacturer as others may render the product unsafe.

Do not load the basket with a weight in excess of 3kg.

If your pushchair is to be used by someone who is unfamiliar with it, e.g. grandparents, then show them how it works before letting them use it.

## Safety warnings (when attached to the compatible Travel System)

### WARNING

Never leave raincovers, hoods and aprons on indoors or in hot weather as your child might overheat.

Do not allow your child to climb unassisted into or out of the pushchair.

This product complies with BS EN 1888-1:2018+A1:2022 and BS EN 1466:2023

## Care and maintenance

Clean minor spills and stains on cloth, vinyl or plastic surfaces with cold water and mild soap. Air dry.

Any plastic and metal parts may be sponged clean with warm water and mild detergent.

Always allow to dry thoroughly before using or storing.

Do not leave the carrycot in direct sunlight for prolonged periods as fabrics may fade.

Never use abrasives, ammonia, bleach or spirit based cleaners.

Always store your carrycot in a dry place.

Regularly inspect the carrycot for damage or wear, paying particular attention to the bottom of the carrycot, handles, chassis attachment points and harness (if fitted).

**WARNING:** Do not use if any part of the carry cot is broken, torn or missing.

**WARNING:** Mattress must be fully dry before storage or usage.

**WARNING:** Mattress may not soak up vomit.

**WARNING:** Parcels, accessories and other items (e.g. hand bags, shopping bags, etc) that are placed on the handles, back of the backrest or sides of the pushchair will affect the stability of the pushchair and can cause failure of one or more components of the pushchair.

### Ride-on platform attachments

This product has not been tested with a ride-on platform. Consult your retailer for suitability if you are considering getting a ride-on platform. Any damage resulting from the use of a ride-on platform will not be covered by the warranty.

### Care of the rain cover

A. The rain cover can be cleaned by sponging with warm water and mild detergent.

B. Ensure raincover is completely dry before storing.

C. If your child tends to kick the cover, simply release the foot Velcro® to avoid damage to the rain cover.

**Warning:** This cover is for outdoor use only. The rain cover must be removed if the child remains in the pushchair indoors, otherwise the child may overheat, also remove the rain cover in warm sunny weather.

**Note:** Do not put in your car on hot days, as this will damage your rain cover.

## Welcome

Thank you for purchasing the Puggle Slimline Twin Duo Carrycot.

Please read the instructions and warnings carefully before use to ensure safe and satisfactory operation of this product.

Your child's safety is your responsibility. If you have a query with this product or require replacement parts, please contact us at [online4baby.com/contact-us](https://online4baby.com/contact-us).

# Parts list

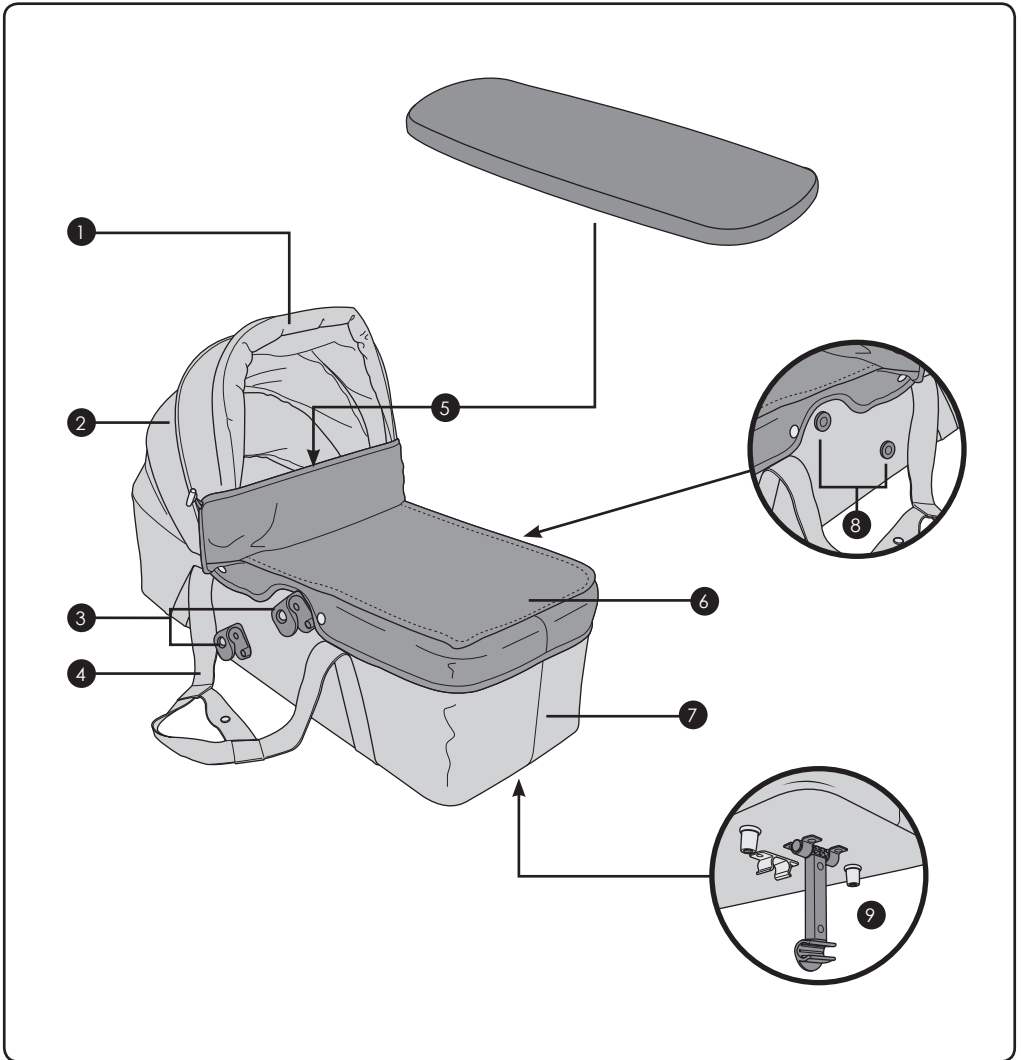

- 1 Handle
- 2 Hood
- 3 Pushchair connector clips
- 4 Carry strap
- 5 Mattress

- 6 Apron
- 7 Carrycot body
- 8 Pushchair connectors
- 9 Support bar

## Identifying your carrycot(s)

left-hand-carrycot  
or "main" carrycot



right-hand-carrycot

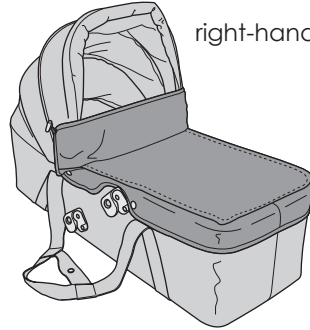

**NOTE!** The left and right-hand sides are based on being stood in front of the stroller.

## Possible combinations

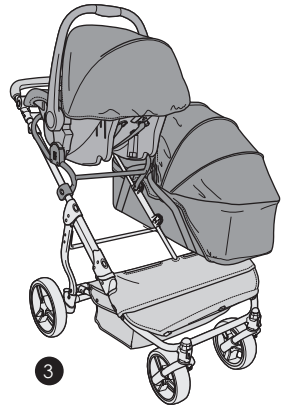

There are two very distinct carrycots and depending on your situation you may require one or both of them.

If you wish to only use one carrycot and no other optional extra, then please use the left-hand or "main" carrycot.

1. Carrycot on left (requires the left-hand or "main" carrycot)
2. Carrycot on both sides (requires the left-hand or "main" carrycot and right-hand carrycot)
3. Car seat\* on left + Carrycot on right (requires upper-left-hand adapter\*\* and right-hand carrycot)

**NOTE!** The left and right-hand sides are based on being stood in front of the stroller.

\* Car Seat sold separately

\*\* Upper-left-hand car seat adapter sold separately

# Attaching the carrycot

Before attaching the carrycots you will need to remove the seat fabric from one or both seats depending on if you wish to use one or two carrycots. If you are using just the left-hand "main" carrycot then you will need to remove the left hand seat fabric. **Note: You cannot remove the right-hand seat fabric without removing the left-hand seat fabric too.**

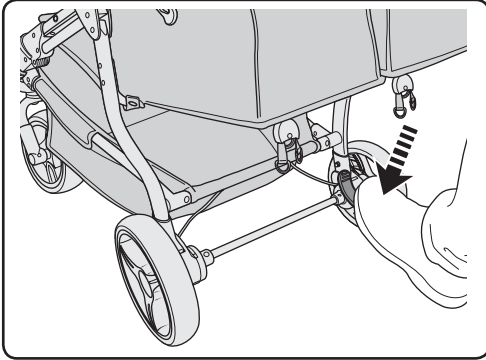

1. **Apply the brake:** Ensure the stroller brake is on and that the stroller cannot move.

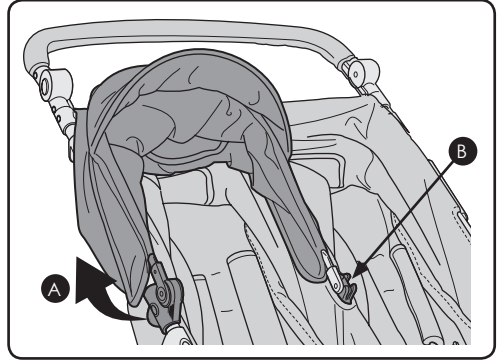

2. **Remove the hood:** Unfasten the press studs on the back of the left-hand hood. Unclip the hood-clip (A) and pull the round connector from the mounting point (B).

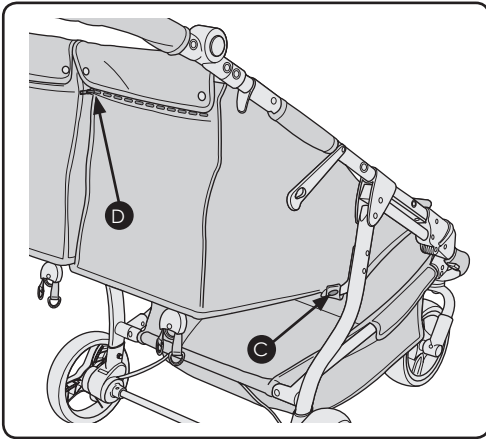

3. **Remove the seat fabric:** Release the two press studs at the back of the seat (C) and undo the zip (D).

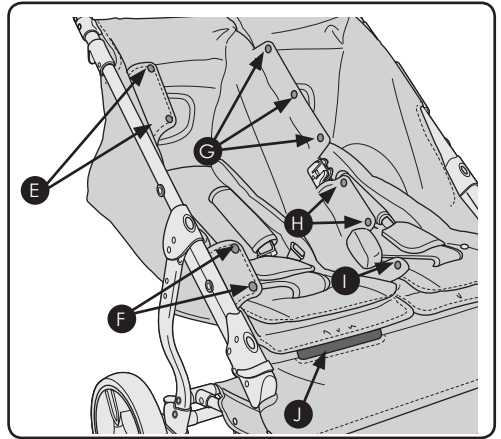

4. **Remove the fabric:** Release all the press studs (E, F, G, H, I). Unfasten the Velcro® tab (J) and remove the seat fabric. Repeat steps 1,2,3 & 4 on the remaining seat if you wish to remove both seat fabrics for two carrycots.

**Note:** Ensure the calf rest is in the lowest position prior to fitting the carry cot.

## Attaching the carrycot (cont)

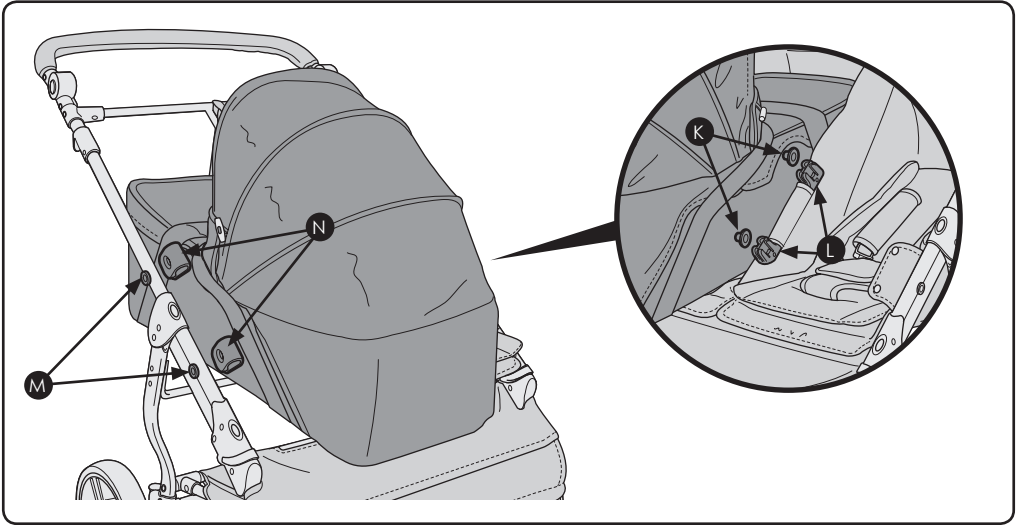

5. **Attach the carrycot:** Line up the carrycot with the stroller so that it is parent facing ensuring the carry straps are kept together on top of the carrycot.

Push both of the round connectors (K) into the mounting points (L) in the middle of the stroller.

Connect both clips (M) over the mounting points (N) on the outside of the stroller.

Pull the carrycot to check both sides are secured properly.

### 6. **Secure the support bar:**

Lower the support bar (O) towards the chassis's rear crossbar and clip the support bar to the crossbar.

Pull the support bar to check it is secured properly.

**IMPORTANT: ALWAYS attach the support bar!**

**Do NOT attempt to attach the carrycot to a seat which has its fabric still attached.**

**The seat fabric must be removed before fitting the carrycot.**

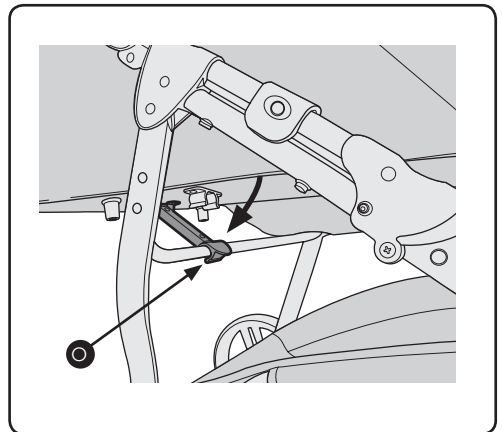



If you have any questions or concerns regarding this product,  
do not hesitate to contact our expert team online  
via [online4baby.com/contact-us](https://online4baby.com/contact-us)

Feeling social?    
[online4baby.com](https://online4baby.com)

Imported by Online4baby Ltd,  
Meadowbank, Tweedale Way, Oldham, OL9 8EH